

# 70x70x25mm

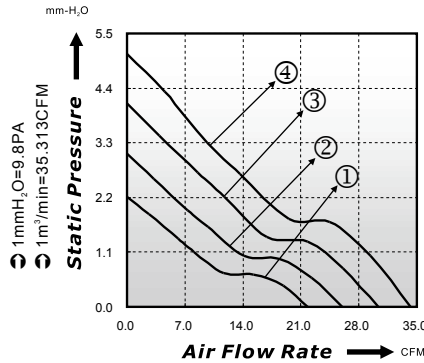

## ■ P-Q Curve (At Rated Voltage)



## ■ Dimensions Drawing

Unit: (mm)

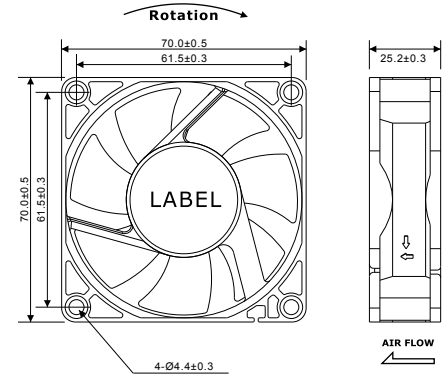

Model No	Bearing (*)	Rated Voltage (VDC)	Rated Current (A)	Power Consumption (Watts)	Speed (rpm)	Air Flow (CFM)	Static Pressure (mmH <sub>2</sub> O)	Noise (dBA)	Curve
ED07025-12L*	○ ● ⊖	12	0.12	1.44	2700	21.78	2.21	24.2	1
ED07025-12M*	○ ● ⊖	12	0.17	2.04	3200	25.98	3.08	28.6	2
ED07025-12H*	○ ● ⊖	12	0.25	3.00	3700	30.34	4.10	32.4	3
ED07025-12HH*	○ ● ⊖	12	0.36	4.32	4200	34.24	5.09	35.9	4
ED07025-24L*	○ ● ⊖	24	0.06	1.44	2700	21.78	2.21	24.2	1
ED07025-24M*	○ ● ⊖	24	0.10	2.40	3200	25.98	3.08	28.6	2
ED07025-24H*	○ ● ⊖	24	0.12	2.88	3700	30.34	4.10	32.4	3

\* Bearing Type: ○ Sleeve ● Two Ball ⊖ Hydro-Dynamic